

# TECHNICAL TIPS

## 7 HIP SUPPORT ADJUSTMENT

To adjust the height of the hip supports, loosen the wing knob and the two other knobs located between the hip and knee supports (**fig. 7a**). Slide to the desired height and retighten the three knobs. To adjust the width of the hip supports, loosen both wing knobs. Slide to the required width, then retighten (**fig. 7b**).

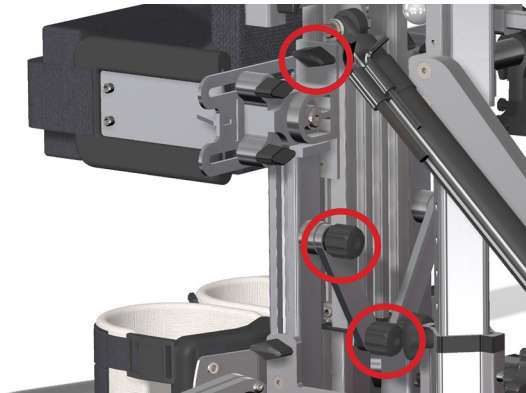

fig. 7a

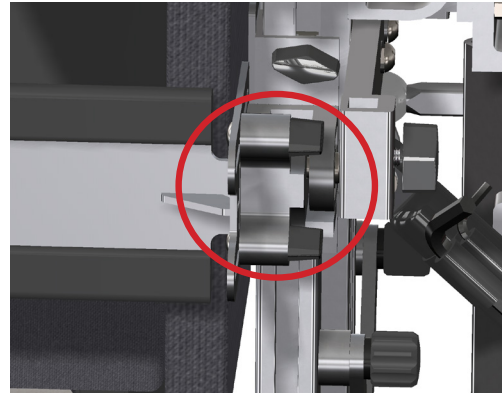

fig. 7b