

Standing Frame **VERTIFLEX** 4-5-6

USER'S MANUAL



Stand **up**
Strong

Synetik
ErgoCare

✉ client@synetikgroup.com

☎ 450-759-9449 / 1-866-739-2400

📍 1242, rue de Lanaudière, Joliette (Quebec), Canada, J6E 3P1

www.synetikergocare.com

R01

INDEX

Groupe Synetik Group

Group Synetik inc. would like to thank you for the trust you have placed in us by choosing the VERTIFLEX multi-position Standing Frame.

The VERTIFLEX S4-S5-S6 is an electric lift that combines functionality, ergonomics and safety to meet your daily needs.

We recommend that you read this manual carefully so that you fully understand its content and operation. This will enable you to quickly familiarize yourself with VERTIFLEX and benefit from many practical tips for safe and efficient use.

By following our recommendations, you'll optimize your development and rehabilitation goals.



Caroline Saulnier
President

Contact us	3
Product overview	4
Product labelling	5
Intended use	5
Warranty	5
Record product history	6
Product training	6
Safety information	7
Required tools	8
Unpacking, charging and use	9
User transfer procedures	12
Frequent adjustments for daily use	13
Cleaning and maintenance	17
Daily inspection	17
Annual inspection, maintenance and replacement parts	18
Batteries replacement	18
Maintenance service	20
Storage	20
Reuse by a new user	20
Technical specifications	21

USER MANUAL

This manual applies to sizes 4, 5 and 6 of the standard VERTIFLEX model.

Dealer : This manual must be given to the user of the VERTIFLEX Standing frame before its first use.

User : Before using the VERTIFLEX Standing frame, read this manual carefully and keep it for future reference.

The masculine gender is used in this manual as a neutral gender. The use of the masculine gender is intended to lighten the text and make it easier to read.

The Synetik Group reserves the right to modify or revise, without notice, the specifications and illustrations in this document.

For more information on products, parts, accessories and services, contact Synetik Group.

VERTIFLEX STANDING FRAME

Thank you for selecting a VERTIFLEX Standing frame. Please do not hesitate to send us your feedback or questions regarding this product's reliability, safety, usability, as well as any repair/maintenance services offered by an authorized Synetik Distributor.

WARNING – READ THIS MANUAL

Do not operate this standing frame without reading and understanding this User Manual. If you are unable to understand the warnings, cautions and instructions, contact your Synetik dealer or customer support at 1 866 739-2400 before attempting to use this standing frame.

If you ignore this Warning, you may fall, tip over or lose control of the standing frame and seriously injure yourself or others and damage your VERTIFLEX standing frame.

Made in Canada with Canadian and imported parts.

CONTACT US

Synetik Group Inc.
1242, rue de Lanaudière, Joliette (Quebec), Canada, J6E 3P1
1-450-759-9449 / 1-866-739-2400
client@synetikgroup.com

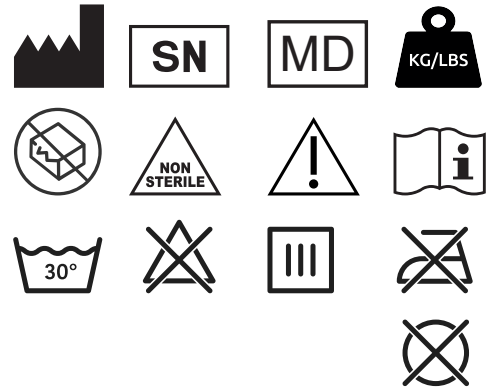

1. PRODUCT OVERVIEW

PARTS LIST

1. Push handle
2. Headrest
3. Headrest support
4. Shoulder support
5. Anchor block for axilla, headrest and shoulders
6. Thoracic support receptacle
7. Hip support receptacle
8. Thoracic support
9. Hip support
10. Padded thoracic strap
11. Padded hip strap
12. Planar
13. Padded half tray
14. Tray
15. Universal tray bar
16. Knee support
17. Footplate
18. Foot support
19. Base
20. Swivel caster
21. Actuator
22. Battery control
23. Controller
24. Frame
25. Mast

VERTIFLEX spine shown

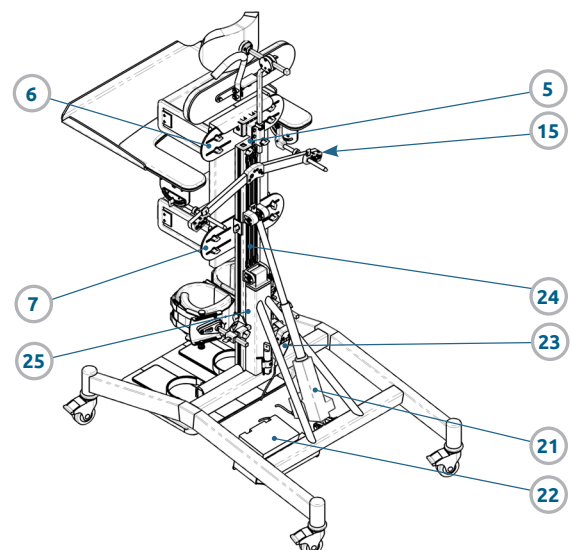
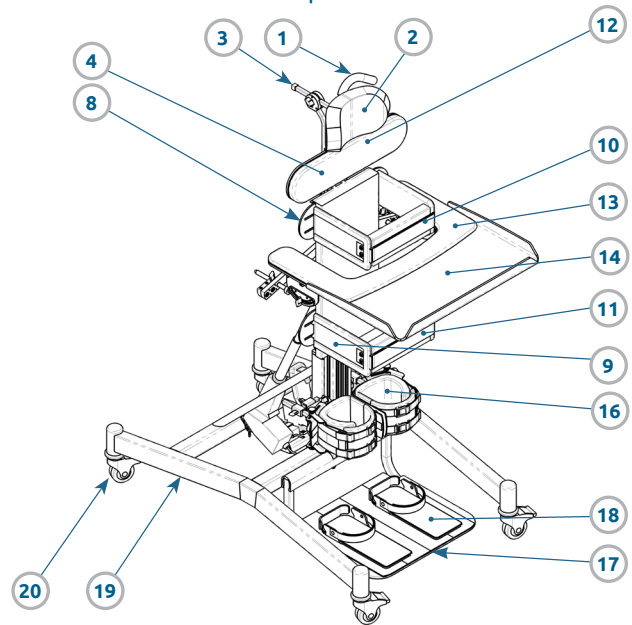

2. PRODUCT LABELLING

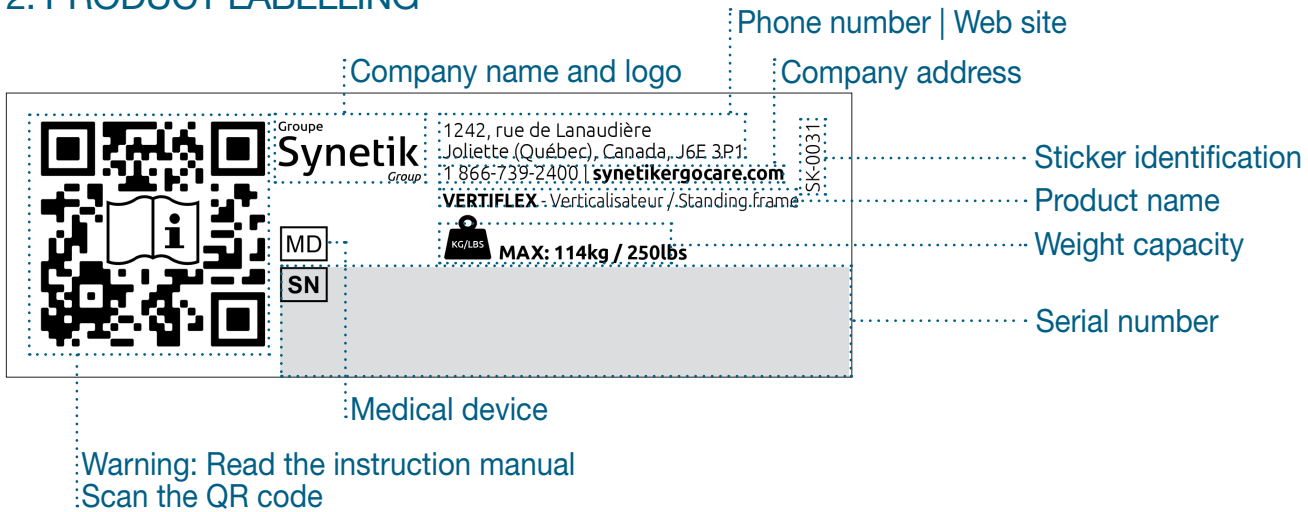

3. INTENDED USE

Synetik VERTIFLEX is designed for use in the standing position, at home, at school or in an institution. Standing promotes normal hip development, strengthens muscles and contributes to psychological well-being.

This multi-position electrical device is available in three sizes to meet the requirements and needs of people with reduced mobility.

	Maximum user weight
Size 4	114 kg (250 lb)
Size 5	114 kg (250 lb)
Size 6	114 kg (250 lb)

4. WARRANTY

4.1 WARRANTY CONDITIONS Warranty coverage is extended to the original user for as long as the original purchaser owns Synetik Group Inc. VERTIFLEX MULTI-POSITION EQUIPMENT. This warranty is in effect for the VERTIFLEX Electric Standing Frame (“the product”). Synetik Group Inc. (“the company”) will repair or replace the product found to be defective in material or workmanship under the following conditions:

Frame: 5 year warranty to original user, subject to terms, limitations and conditions.

Actuator: One (1) year warranty to original user, subject to terms, limitations and conditions.

Straps: One (1) year warranty to original user subject to terms, limitations and conditions.

Other components : Cover, upholstery, plastic parts, rubber parts, wheels, bearings and other parts not specifically identified above, are warranted against defects in materials and workmanship for three (3) months from the date of original purchase, subject to the terms, limitations and conditions.

4. WARRANTY (continue)

4.2 WARRANTY TERMS

This warranty will be in effect from the date of original purchase for the consumer. Any defective product must be delivered to Synetik Group Inc. or its authorized local dealer, at the purchaser's expense, for warranty inspection. Return freight charges will be prepaid by Synetik Group Inc. You can contact Synetik Group Inc. at 450-759-9449 for authorized dealers in or near your location.

4.3 LIMITS AND EXCLUSIONS

The warranty provided above does not apply to (a) a serial numbered product if the serial number has been removed or defaced; (b) any product subjected to negligence, abuse, misuse, improper operation, maintenance or storage, or damage beyond the control of Synetik Group Inc. as determined by Synetik Group Inc.; (c) defects resulting from failure of the user to follow instructions. Any modification or addition to the product of unauthorized parts not manufactured or supplied by Synetik Group Inc. The repair or replacement by Synetik Group Inc. of a defective part or product will be the purchaser's sole and exclusive remedy under the warranty. Repair labor/service charges are not covered by this warranty and are not the responsibility of Synetik Group Inc.

The foregoing warranty is exclusive and in lieu of all other warranties, express, implied or statutory, including all warranties of merchantability and/or fitness for a particular purpose. In no event shall Synetik Group Inc. be liable for indirect or consequential damages.

5. RECORD PRODUCT HISTORY

Your Synetik product is classified as a Class 1 medical device and, as such, should only be prescribed, configured or reissued for use by a technically competent person who has been trained in the use of this product. Synetik Group Inc. recommends that a written record be kept to provide details of all configurations, reissue inspections and annual inspections of this product.

6. PRODUCT TRAINING

Your Synetik product is a prescribed Class 1 medical device and as such, Synetik Group Inc. recommends that parents, teachers and caregivers using the equipment be informed of the following sections of this user manual by a technically competent person:

Section 6: Safety information

Section 10: User transfer procedures

Section 11: Frequent Adjustments for Daily Use

Section 13: Daily Product Inspection

Synetik Group Inc. recommends that a written record be kept of all those who have been trained in the proper use of this product.

7. SAFETY INFORMATION

7.1 GENERAL INSTRUCTIONS

- Always read the instructions before use. Failure to read and follow the operating instructions, especially those concerning moving parts, may present a risk to the user.
- Use only Synetik-approved components with your product. Never modify the product in any way. Failure to follow instructions may endanger the user or caregiver and will void the product warranty.
- If you have any doubts about the continued safe use of your product, or if any parts fail, please stop using the product and contact our customer service department or your local dealer as soon as possible.
- The product contains components that could present a choking hazard to young children. Always check that buttons and locking bolts within the child's reach are tight and secure at all times.
- Clean the product regularly. Do not use abrasive cleaners. Carry out regular maintenance checks to ensure that your product is in good working order.
- Ensure that the prescriber has confirmed that the product is correctly configured. If the product has not been configured by your prescriber, DO NOT USE.
- Ensure that all persons handling the product are familiar with its operation and have read the instructions for use.
- The product is designed for indoor use, and when not in use should be stored in a dry place not subject to extreme temperatures. The product's safe operating temperature range is +5 to +40 degrees Celsius.
- Do not use this product if it is damaged or broken.
- If, against all expectations, a serious incident should occur with the product, please report it immediately to our company and the relevant authorities.
- We reserve the right to make technical modifications. This may result in differences between your product and its presentation in the media.

7.2 SAFETY INSTRUCTIONS

- Synetik Group Inc. recommends that the user never be left unattended while using this medical device. If left unattended, the user may slip or fall, resulting in serious injury. It is the sole responsibility of the person caring for the user of this medical device to ensure the safety of the user in the device when left alone.
- It is essential that Synetik Group Inc. products be carefully inspected at least annually and periodically by a qualified prescriber for proper use and suitability for the user's needs. The examiner is responsible for ensuring that each product is safe and stable during use, paying particular attention to users whose clinical presentation or body size may have changed since the initial purchase, or where the user now exhibits challenging behaviors and movements that compromise product stability, such as excessive rocking.
- Make all positional adjustments and ensure they are securely fastened prior to installing the user in this product.

7. SAFETY INFORMATIONS (continue)

7.2 SAFETY INSTRUCTIONS (suite)

- When placing the user in the harness, always fasten the lap belt first for safety. The chest and knee straps should then be attached.
- When the product is stationary, make sure that all wheels are locked and facing away from the base as this improves stability.
- Never adjust the overall height of the unit while it is in use. Other minor positional adjustments can be made safely while the user is inside the unit.
- DO NOT use the unit on slopes greater than 5 degrees angle. Remember to lock all wheels.
- This product contains plastic components and should be kept away from all direct sources of heat, including naked flames, cigarettes, electric and gas heaters.
- DO NOT place hot objects on the tray above +40 degrees Celsius.
- Always ensure that the straps fit snugly around the user and that the strap buckles are securely fastened to prevent slipping, falling and serious injury during use.
- DO NOT leave the user unattended while getting on or off the product.
- Always check the wheel brakes for proper operation before using the product. If the brakes do not function properly, do not use the product.
- NEVER add weights other than the user's to prevent the product from tipping over.
- NEVER use the product for transportation in a vehicle.
- NEVER use the product on an escalator.
- NEVER descend stairs with the user inside the product.
- NEVER move the product while the user is inside.
- NEVER feed the user while he/she is inside the Vertiflex. First aid cannot be administered in the event of choking.
- The product should only be used by one user at a time.

8. REQUIRED TOOLS

Supplied with the product:

- Allen Key to assemble the product and adjust certain components (Fig. 8a).
- Wrench for tightening the locking knobs (Fig. 8b).



Fig. 8a
Allen Key



Fig. 8b
Tightening Wrench

9. UNPACKING, CHARGING AND USE

9.1 UNPACKING

WARNING: After unpacking the product, check that all parts are present and that the equipment is undamaged and that the equipment is undamaged. If any parts are damaged or missing contact Synetik Customer Service (see page 3).

- Check that the packaging has not been damaged in transit and that the product is in perfect condition.
- Carefully remove the packaging from the product.
- Ensure that packaging material and small parts do not fall into the hands of small children, to avoid the risk of choking.
- The product is delivered assembled, adjusted and ready for use.
- Handle the product carefully and safely at all times.

9.1.1 ENVIRONMENT PROTECTION (fig. 9.2)

Packaging materials are recyclable. Please do not dispose of packaging materials in the household trash. Please recycle them.

The charger (9.2a) and batteries (9.2b) contain materials that must not be disposed of in landfills. Please dispose of them according to your local waste collection system.

9.2 COMPONENT IDENTIFICATION

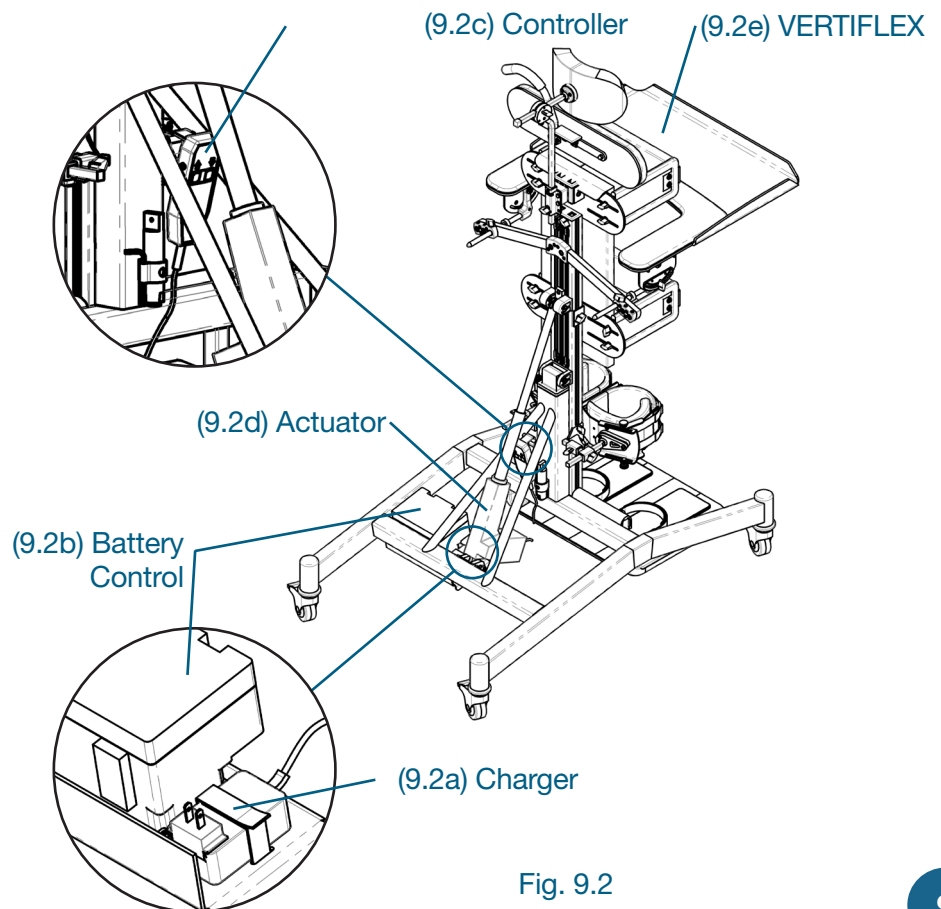
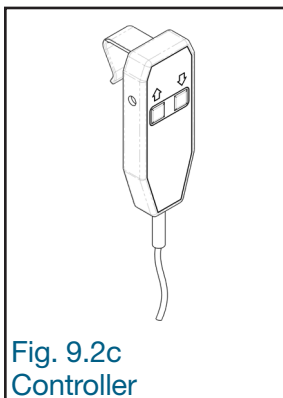
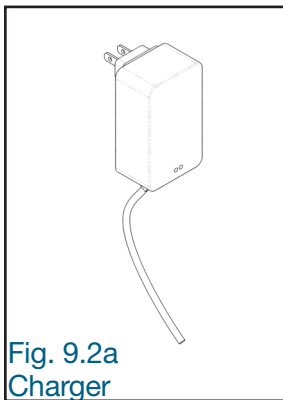

9. UNPACKING, CHARGING AND USE (continue)

9.3 BATTERY CHARGING

WARNING: Do not remove, destroy, or paint over warning labels.

Read the following safety instructions carefully before using the battery charger.

9.3.1 SAFETY INSTRUCTIONS

Your safety and the safety of others is very important. The safe use of this charger is an important responsibility. In addition to the information in this manual, you must also follow all legal safety and accident prevention regulations.

- Ensure that the batteries are fully charged by checking the charge indicator on the charger.
- Check the charger regularly to ensure that it has not been damaged.
- The device is only suitable for indoor use at temperatures between +5 and +40 degrees Celsius. Do not use outdoors.
- Do not use the battery charger when it is wet or when your hands are wet.
- Do not expose the charger to rain.
- Do not cover the charger during use.
- Do not open the battery charger. Repairs should only be made by authorized personnel by the manufacturer.
- Replace damaged cables immediately.
- Never use an extension cord when charging batteries.
- When charging batteries, make sure the charger plug is fully inserted into the 110V outlet.
- Unplug the charger when the batteries are fully charged. Do not leave the charger plugged in after charging.
- Do not use the equipment while the batteries are charging.
- Do not leave charging batteries unattended.
- Only use the charger supplied with the device to recharge the batteries. Using a different charger will void Synetik's liability for any damage that may be caused to the device.

See figure 9.2 for the location of the batteries (9.2b), charger (9.2a) and controller (9.2c).

9.3.2 CHARGING (Fig. 9.3)

The VERTIFLEX is equipped with (2) AMG 12V-2.9Ah sealed batteries. The batteries (9.3d) are charged using the controller (9.3c). To recharge the batteries (9.3d), simply connect the power supply plug (9.3h) of the charger (9.3a) to a 110V outlet (9.3b), then connect the power cord (9.3i) of the charger (9.3a) to the battery charging socket (9.3g) on the left side of the controller (9.3c).

The charger (9.3a) is equipped with an indicator light (9.3f) to show the charging status of the batteries (9.3d). When the charger (9.3a) is connected, a green light indicates that the batteries (9.3d) are fully charged, while a yellow light indicates that the batteries (9.3d) need to be recharged. The batteries (9.3d) are recharged in less than two hours.

9.3.3 BEFORE EACH USE (fig. 9.3)

Make sure that the batteries (9.3d) are fully charged. To check that the batteries (9.3d) are fully charged, simply connect the plug (9.3h) of the charger (9.3a) to a 110V outlet (9.3b), then connect the cable (9.3i) of the charger (9.3a) to the battery charging socket (9.4.2a) on the left of the controller (9.3c).

If the indicator light (9.3f) is green, the battery is charged and ready for use.

If the indicator light (9.3f) is yellow, refer to sections 9.3.1 and 9.3.2 for the battery charging procedure.

9. UNPACKING, CHARGING AND USE (continue)

9.3 BATTERY CHARGING (suite)

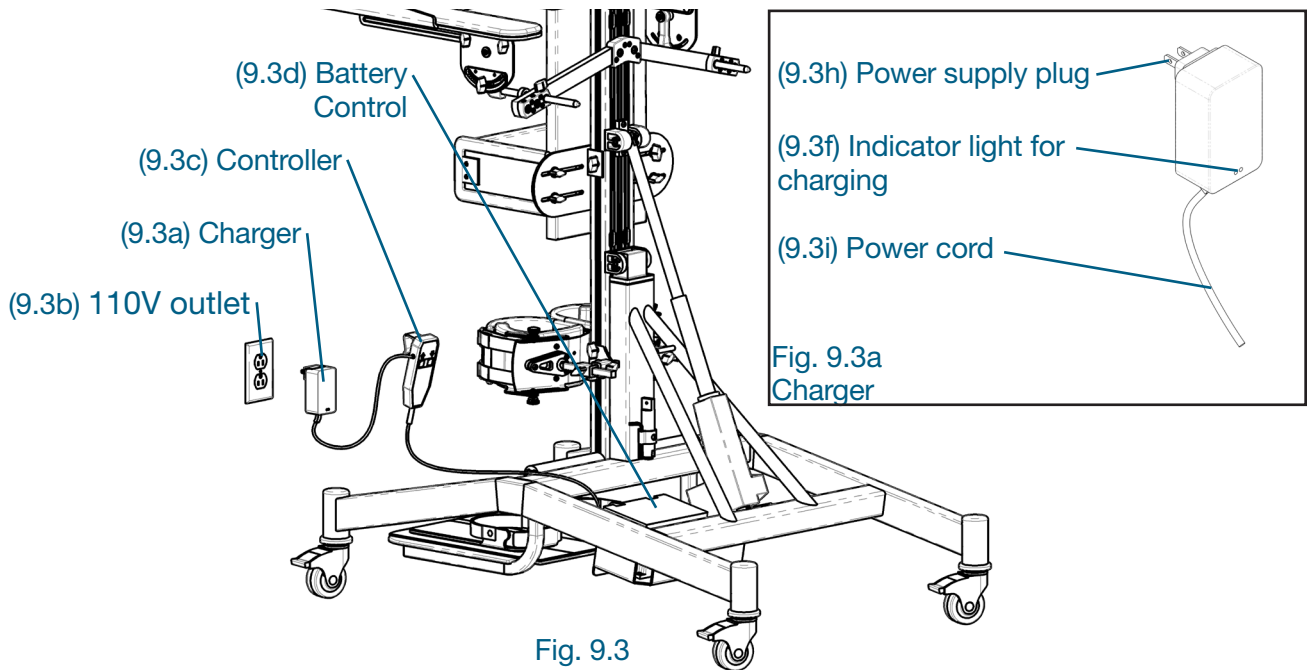

9.4 CONTROLLER OPERATION (fig. 9.4)

9.4.1 ACTIVATION OF VERTIFLEX INCLINATION

The VERTIFLEX tilts effortlessly in seconds thanks to an actuator activated by a simple controller.

Tilting backwards

Press the left button (9.4.1a) marked with an upward arrow until the desired tilt is reached, then release.

Vertical leveling

Press the right-hand button (9.4.1b) marked with a downward arrow until the desired straightening position is reached, then release.

9.4.2 BATTERY CHARGING SOCKET

Simply connect the charger plug to a 110V outlet, then connect the charger cord to the charging socket on the controller (9.4.2a). Please refer to sections 9.3.1 and 9.3.2 for battery charging procedures.

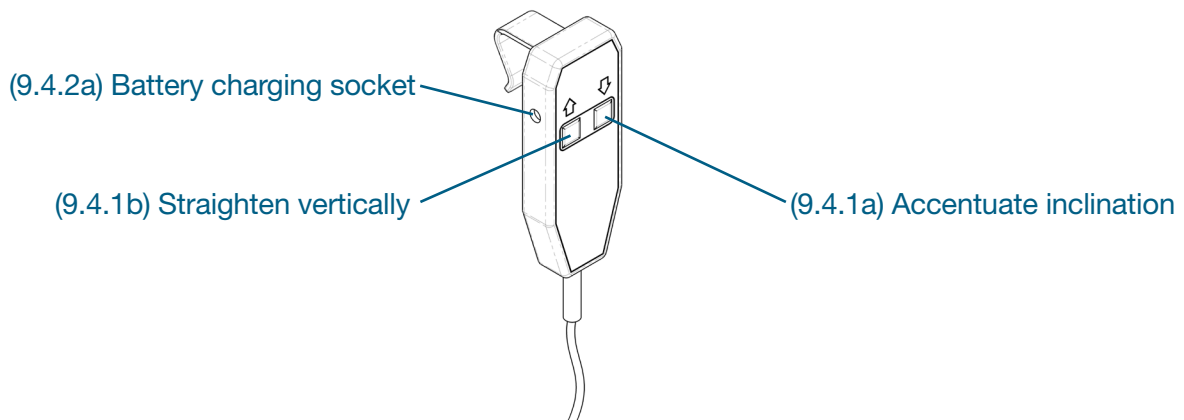

Fig. 9.4

10. USER TRANSFER PROCEDURES

10.1 SAFETY INSTRUCTIONS

Before entering or exiting the product, please read the following instructions carefully:

- The unit must be placed on a smooth, level surface;
- All wheels must be securely locked;
- DO NOT leave the user unattended while transferring into or out of the product;
- The user must be transferred by a trained healthcare professional or caregiver;
- Transfer techniques may vary from person to person depending on the user's medical condition.

10.2 TRANSFER

10.2.1 VERTIFLEX PRONE TYPE (fig. 10.2.1)

1. Position VERTIFLEX vertically.
2. Securely lock all wheels.
3. Make sure that all laterals (thoracic, hips, knees) are unobstructed.
4. The user can now enter the VERTIFLEX. To facilitate the transfer, the user can hold onto the side of the thoracic lateral (B).
5. Adjust and buckle the support straps in the following order:
 - 1) Hip lateral strap (A);
 - 2) Thoracic lateral strap (B);
 - 3) Knee lateral straps (C).

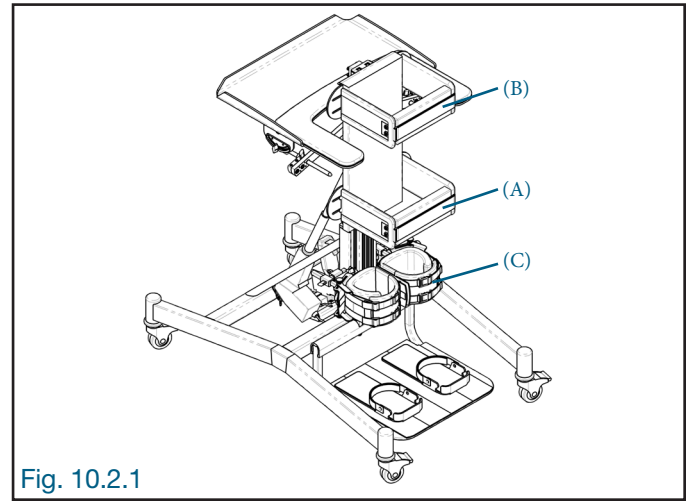

Fig. 10.2.1

10.2.2 VERTIFLEX SUPINE TYPE (fig. 10.2.2)

1. Remove table.
2. Position VERTIFLEX horizontally.
3. Securely lock all wheels.
4. Make sure all laterals (thoracic, hips, knees) are unobstructed.
5. Gently transfer the user to the equipment.
6. Adjust and buckle support straps in the following order:
 - 1) Hip lateral strap (A);
 - 2) Thoracic lateral strap (B);
 - 3) Knee lateral straps (C).
7. Straighten VERTIFLEX to vertical position.
8. Install and adjust table.

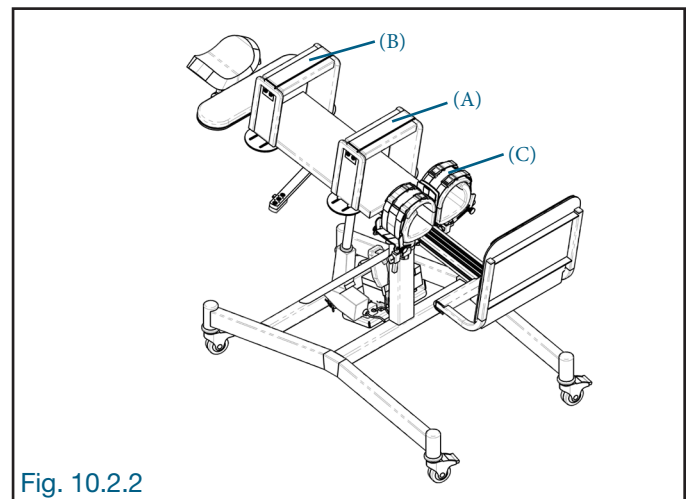

Fig. 10.2.2

11. FREQUENT ADJUSTMENTS FOR DAILY USE

11.1 ADJUSTMENT PROCEDURES (fig. 11.1)

Periodically check all device settings and ensure that they are always adapted to the user's current body dimensions. If necessary, have the settings adjusted by a specialized technician or therapist.

NOTE: If you have difficulty reaching or firmly tightening a locking knob (A) for adjustment, use the tightening tool (B) provided for this purpose.

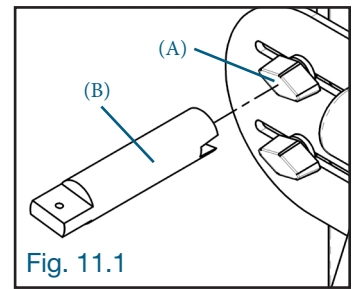

Fig. 11.1

11.2 TILT ADJUSTMENT (fig. 11.2)

When changing the inclination of the unit, ensure that :

- The wheels are securely locked;
- No part of the user's or caregiver's body can become trapped while the tilt is being changed;
- All straps and other attachments are securely in place and properly adjusted to the user, so as not to compromise safety;
- The unit is at the right distance from surrounding furniture to avoid potential collisions.

To tilt or straighten the unit, activate the actuator (A) using the controller (B). Refer to section 9.4 to learn more about the controller.

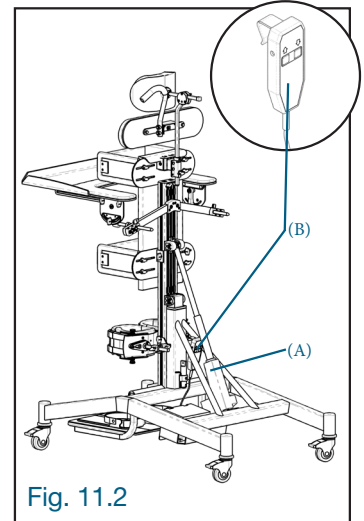

Fig. 11.2

11.3 WHEEL LOCKING (fig. 11.3)

Each of the four wheels has a brake (A). Ensure that the four-wheel brake (B) is locked when the product is being used, adjusted or stored.

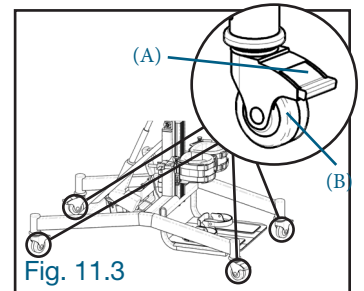

Fig. 11.3

11.4 FOOT SUPPORT ADJUSTMENT (fig. 11.4)

The foot supports (A) are secured by hook-and-loop fasteners (B), enabling them to be moved to the ideal position for the user. Once in position, release the hook-and-loop fastener (C) and slide the foot into the foot support (A). Secure the foot with the hook-and-loop strap (C), folding it over the top of the foot near the ankle.

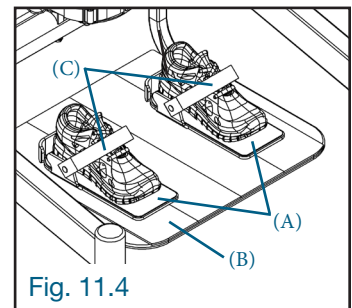

Fig. 11.4

11. FREQUENT ADJUSTMENTS FOR DAILY USE (continued)

11.5 KNEE SUPPORT ADJUSTMENT

Height adjustment (fig. 11.5a)

Loosen the (2) locking knobs (A), slide the knee-stop bracket (B) onto the frame (F) to the desired position, then retighten the locking knobs (A).

Depth adjustment (fig. 11.5a)

Loosen the locking knob (C) located on the crossbar of the knee-stop bracket (B), slide to the required measurement and then retighten the locking knob (C) firmly.

Width adjustment (fig. 11.5a)

Loosen the locking knob (D) on the side of the knee-bumper bracket (B), slide to the required measurement and then retighten locking knob (D) firmly.

Tilt adjustment (fig. 11.5b)

Loosen clamping screw (E), turn knee stop (B) on its pivot (G) to the required angle, then retighten clamping screw (E).

Adjusting straps (fig. 11.5c)

The straps (A) of the knee stops (B) must be adjusted and tightened to the user's body so as to hold it in place. To do this, adjust the length of the straps (A) by sliding them over the buckles (C) to the required length. Once adjusted, fasten buckles (C) securely.

11.6 ABDUCTION POMMEL ADJUSTMENT

Height adjustment (fig. 11.6)

Using the Allen key (A), loosen the (2) clamping screws (B), slide the abduction knob (C) onto the frame (D) to the required position, then retighten the clamping screws (B) firmly.

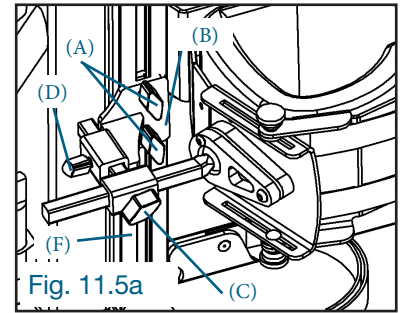

Fig. 11.5a

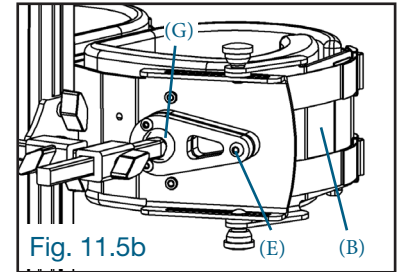

Fig. 11.5b

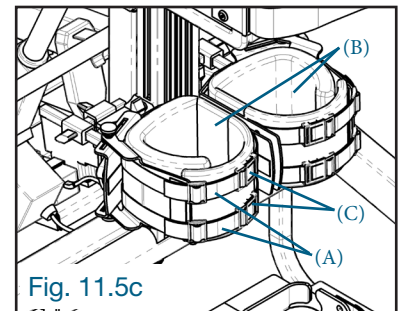

Fig. 11.5c

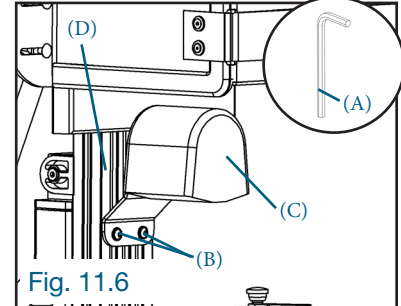

Fig. 11.6

11. FREQUENT ADJUSTMENTS FOR DAILY USE (continued)

11.7 HIP SUPPORT ADJUSTMENT

Height adjustment (fig. 11.7a)

Slightly loosen the locking knobs (A) on either side of the frame (C), on the back of the hip lateral (B), adjust the height of the hip lateral (B) on the frame (C) and retighten the locking knobs (A) firmly.

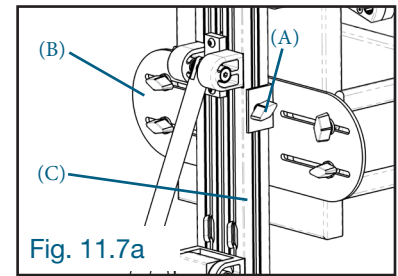

Fig. 11.7a

Width adjustment (fig. 11.7b)

Slightly loosen the (4) locking knobs (A) on the back of the hip lateral (B). Slide and adjust the side laterals (C) to the user's hips. Once adjusted, tighten the locking knobs (A) firmly.

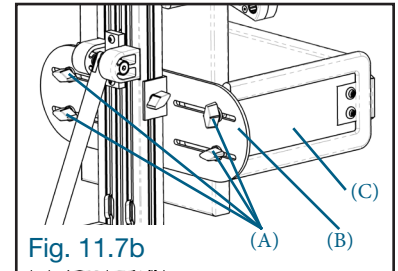

Fig. 11.7b

Strap adjustment (fig. 11.7c)

Insert the strap (A) into the metal loop (B), then fold the strap (A) over itself using the hook-and-loop fastener.

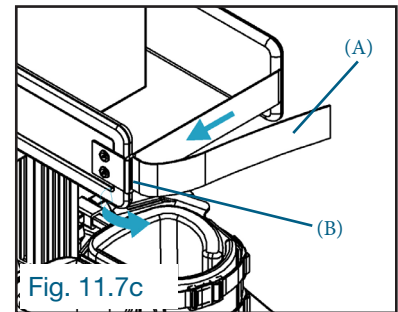

Fig. 11.7c

11.8 THORACIC ADJUSTMENT

Height adjustment (fig. 11.8a)

Using the Allen key (A), slightly loosen the (2) screws (B) on either side of the thoracic stop block (C). Slide the chest stop block (C) onto the rods (D) until the desired height is reached, then retighten the screws (B). It is recommended to adjust the height of the thoracic lateral after adjusting the height of the shoulder support (section 11.9).

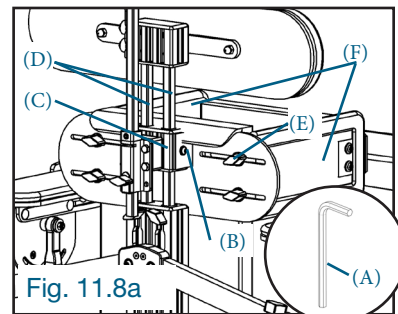

Fig. 11.8a

Width adjustment (fig. 11.8a)

Loosen the (4) locking knobs (E) on the back of the thoracic lateral. Slide and adjust the lateral stops (F) to the width of the user's trunk. Firmly tighten the (4) locking knobs (E).

Strap adjustment (fig. 11.8b)

Insert the strap (A) into the metal loop (B), then fold the strap (A) over itself using the hook-and-loop fastener.

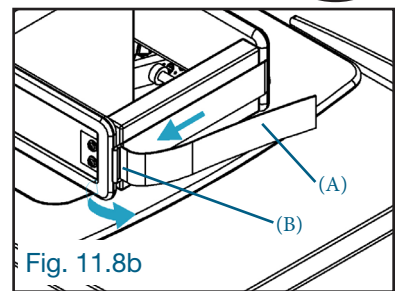

Fig. 11.8b

11.9 SHOULDER SUPPORT ADJUSTMENT

Height adjustment (fig. 11.9)

Loosen the (2) locking knobs (A), adjust the shoulder support (B) by sliding it to the desired height, then retighten the screws (A). It is recommended to adjust the height of the shoulder support before adjusting the height of the thoracic lateral (section 11.8).

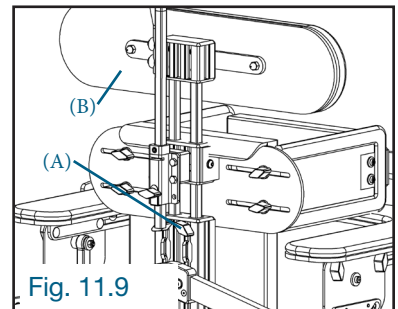

Fig. 11.9

11. FREQUENT ADJUSTMENTS FOR DAILY USE (continued)

11.10 HEADREST ADJUSTMENT

Height adjustment (fig. 11.10)

Using the Allen key (A), slightly loosen the screw (B) on the locking ring (C). Also, slightly loosen the locking knob (D). Slide the headrest rod (E) (F) into the desired position, then tighten the locking knob (D). Position the locking ring (C) against the headrest support (G) and retighten the locking ring (C) screw (B).

Depth adjustment (fig. 11.10)

Slightly loosen locking knob (H), then slide rod (J) forwards or backwards. Once the headrest (F) is in position, retighten knob (H).

Tilt Adjustment (Fig. 11.10a)

Using the Allen key (A), slightly loosen the three clamping screws (B) and pivot the headrest (C) to the desired position. Once the headrest (C) is positioned, tighten the clamping screws (B).

Headrest Support Tilt Adjustment (Fig. 11.10a)

Using the Allen key (A), slightly loosen the two clamping screws (E) and pivot the joint (F) of the headrest support (G) to the desired position. Once the headrest support (G) is positioned, tighten the clamping screws (E).

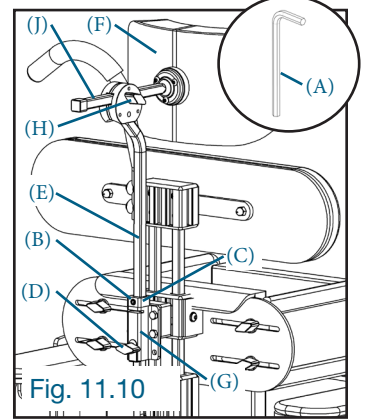

Fig. 11.10

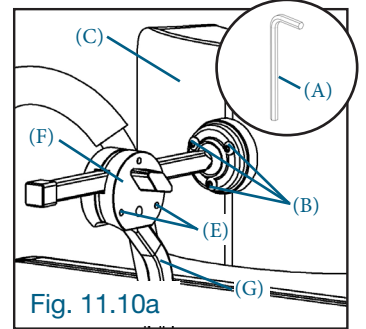

Fig. 11.10a

11.11 TRAY ADJUSTMENT

Installation (fig.11.11a)

Insert the (2) table rods (A) into the round guides (B) above the hips. Slightly lift the front of the table upwards to slide easily and release it in the desired position. Tighten the locking knob (C) above the round slide (B) to secure the table.

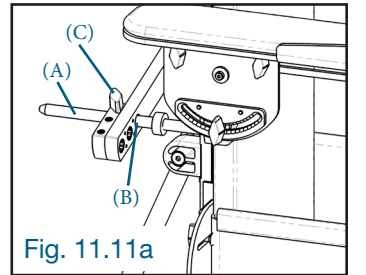

Fig. 11.11a

Tilt adjustment (fig. 11.11b and 11.11c)

Loosen the locking knobs (A) on either side of the table. Tilt the table to the desired angle, then retighten the locking knobs (A).

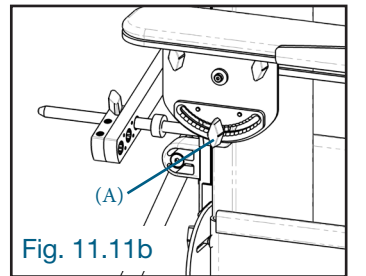

Fig. 11.11b

Adjusting forwards or backwards (fig. 11.11d)

Using the Allen key (A), slightly loosen the screw on the underside of the positioning ring (B). Loosen the (2) locking knobs (C) on either side of the table. Slide the table forward or backward on its slide to the desired position, then retighten the (2) locking knobs (C). Replace the positioning ring (B) in the desired position and tighten the screw underneath. This positioning ring (B) serves to maintain the ideal position for the user. It is usually positioned close to the support bar (D).

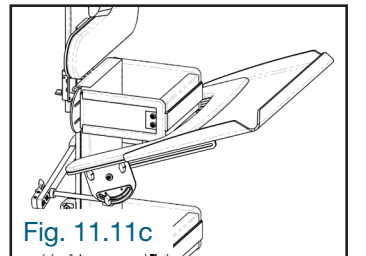

Fig. 11.11c

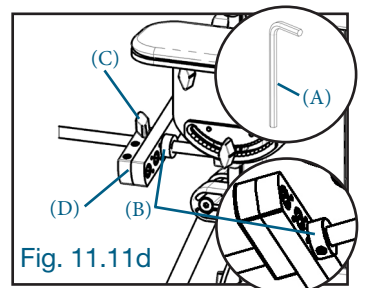

Fig. 11.11d

11. FREQUENT ADJUSTMENTS FOR DAILY USE (continued)

11.11 TRAY ADJUSTMENT (continued)

Height adjustment (fig. 11.11e and 11.11f)

Using Allen key (A), slightly loosen the (2) screws (B) on support bar (C). Adjust support bar (C) to desired height and retighten screws (B). If the table is too high or too low, the support bar (C) can be reversed.

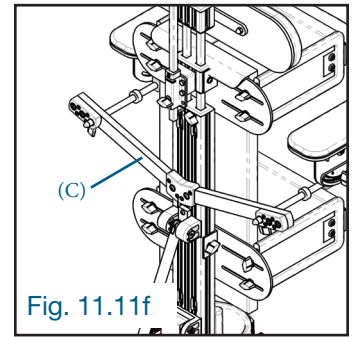
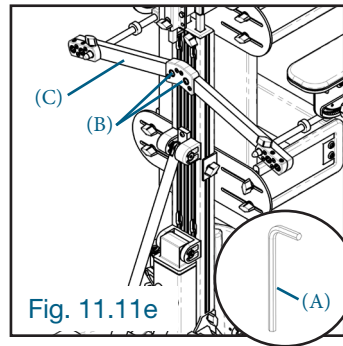

12. CLEANING AND MAINTENANCE

12.1 CLEANING

When cleaning the product, we recommend using only lukewarm water and a non-abrasive detergent. Never use organic solvents, bleach or dry-cleaning fluids.

12.2 PADDING AND FABRICS

- It is normal for fabric to fade after long exposure to sunlight and frequent washing. Also, to show signs of wear after long periods of use, even with normal use.
- Upholstery and fabrics can be cleaned by hand in place. When cleaning, we recommend using only lukewarm water and a non-abrasive detergent.
- The best cleaning method is the “wipe and dry” technique.
- Stains should be removed as quickly as possible with an absorbent cloth, towel or sponge. Mild soap and a sponge in lukewarm water are effective for ordinary dirt and minor spills. Be careful not to over-wet the fabric, as this will cause the stain to spread.
- Antiseptic cleaning agents can be used on the most stubborn stains. These may require a solvent such as isopropyl alcohol or mineral spirits. Half a cup of bleach per 5 liters of water can also be used as a disinfectant.
- Always ensure that the product is dry before use.
- Padded components such as the thoracic, hip and knee supports are made up of a fabric cover that can be removed for machine cleaning and air drying.
- To keep hook-and-loop fasteners operational, clean them from time to time with a brush. When washing components with hook-and-loop fasteners, always close or cover them.

12.3 METAL AND PLASTIC COMPONENTS

- Soap and water or antibacterial spray can be used for daily cleaning.
- For thorough cleaning, low-pressure steam cleaning can be used.
- Do not use solvents to clean plastic, wood or metal components.
- Make sure the product is dry before use.

13. DAILY INSPECTION

Synetik Group Inc. recommends that a daily visual inspection be performed by a therapist, parent or caregiver prior to use, to ensure safe use of the device. At each visual inspection, you should check and make sure that :

- There are no breaks, tears or missing parts. If in doubt, stop using the unit immediately and contact our customer service department;
- All protective covers and straps show no signs of wear or breakage;
- Strap buckles are fasten properly and are not damaged;
- Wheels turn, swivel freely and lock securely;
- The footplate is securely fastened to the frame;
- All locking knobs are in place and tight.

14. ANNUAL INSPECTION, MAINTENANCE AND REPLACEMENT PARTS

14.1 ANNUAL INSPECTION

Synetik Group Inc. recommends an annual inspection of the unit. Be sure to inspect the operation and condition of components (breakage, cracks, wear affecting the structural integrity or safe operation of the product).

List of components to check :

- Base/wheels/brakes;
- Frame/hinge;
- Table;
- Foot plate;
- Actuator;
- Battery/charger/controller;
- Upholstery/covering;
- Straps/buckles;
- Plastic parts;
- Metal parts;
- Locking knobs;
- Nuts/bolts.

14.2 MAINTENANCE AND REPAIR

Maintenance and repairs must be carried out only by qualified personnel. The user of this product must ensure that the prescribed checks and maintenance are carried out regularly and in good time. If any damage is evident, the user must actively report it and have it repaired immediately by qualified personnel.

14.3 REPLACEMENT PARTS

- Only original spare parts may be used for repairs.
- If a part is missing or damaged, stop using the product immediately and contact a Synetik Group Inc. authorized representative. Replacement parts can be ordered separately through a Synetik Group Inc. authorized agent or our customer service department.
- Disassembly and assembly of spare parts must only be carried out by qualified personnel.
- In the event of a necessary return, please ensure that the product is securely packaged for transport.

15. BATTERIES REPLACEMENT

15.1 SAFETY INSTRUCTIONS

Please note that the unit is fitted with (2) AMG 12V-2.9Ah spill-proof batteries.

Before replacing the batteries, please read the following instructions:

- Never place metal objects or conductive materials on either battery terminal.
- Store in a dry, ventilated area at room temperature.
- Keep batteries out of the reach of children.
- Only replace batteries of the same type or equivalent.
- Always use batteries supplied by the manufacturer.
- Batteries contain materials that should not be disposed of in landfill sites. Please dispose of them according to the appropriate waste collection systems in your area.
- Follow the procedures and order for removing and fitting batteries to the unit.
- If in doubt about battery replacement procedures, please contact Synetik Customer Service at +1 450 759-9449.

15. BATTERIES REPLACEMENT (continued)

15.1 REMOVING OBSOLETE BATTERIES

1. Remove the case cover by pressing on the (4) case clips (A) (fig. 15a).
2. Remove the (2) foam wedges (B) holding the (2) batteries in place (fig. 15d).
3. Slightly lift the (2) batteries at the same time to gain access to the underside of the batteries, inside the case.
4. Disconnect the connector (C5) under the batteries, linking the batteries to the controller (C), located in the center of the bottom of the case (fig. 15c).
5. For each battery, there are (2) wires connected. For each of these wires, slide the protective sleeve (D) over the wire to release the connector (G) from its protection, then disconnect the connector (G) from the battery terminal (E) by pressing lightly under it (fig. 15b).
6. Remove the (2) expired batteries and retain the wires for connecting the new batteries.

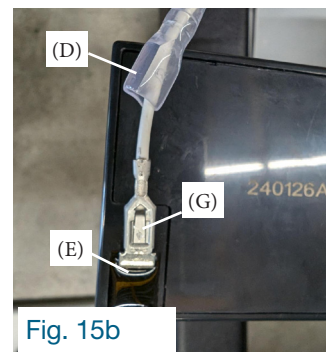
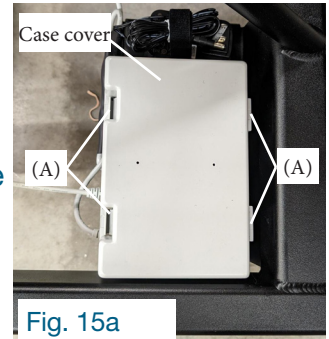

15.2 INSTALLATION OF NEW BATTERIES

1. (fig. 15c) Once the old batteries have been removed (refer to section 15.1), connect the (4) wire connectors to the new battery terminals, taking care to connect each wire as follows:

- White wire (F1) to terminals (B1) and (B4);
- Black wire (F2) to terminal (B2);
- Red wire (F3) to terminal (B3).

2. Once all wires are connected to the terminals of the (2) batteries, connect the connector (C5) to the controller located in the center of the bottom of the case (C) (fig. 15c). Make sure you insert the connector (C5) on the correct side and that it is securely in place. If the connector (C5) is not properly plugged in, sparking may occur, charring the controller.

3. Insert the (2) batteries into the housing in their respective positions. Ensure that the battery connectors and wires face the bottom of the case, and that the battery terminals face the front of the VERTIFLEX (fig. 15d).

4. Using a flathead screwdriver, insert the (2) foam wedges (B) on each battery, on the same side of the case. These hold the batteries in place (fig. 15e).

5. Perform a tilt test on the VERTIFLEX using the control lever to check that it is working properly. If the test is inconclusive, proceed with the following checks:

- All connectors are connected;
- No connectors are loose;
- Batteries are fully charged.

If the unit does not work after checking these points, repeat the procedures in section 15.2 or contact Synetik Customer Service at +1 450 759-9449.

6. Insert and clip the case cover onto the case. Make sure the cover is securely in place before using the unit (fig. 15a).

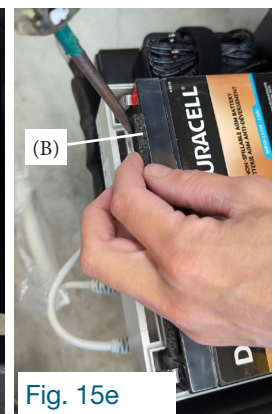
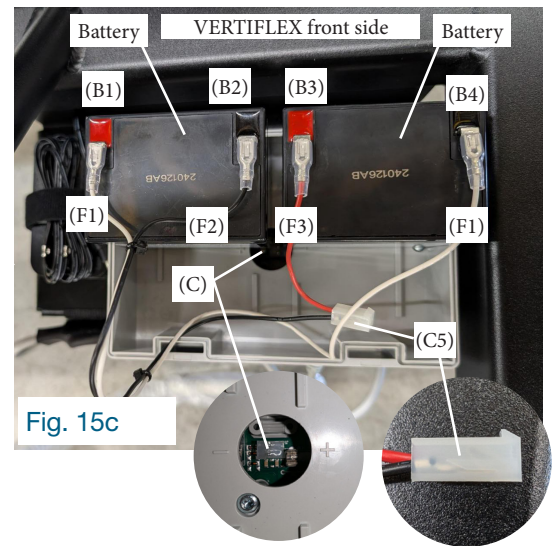

16. MAINTENANCE SERVICE













All Synetik products should only be serviced by technically competent persons who have been trained in the use of the product. In Canada, please contact the Synetik Service Center at +1 450 759-9449 and our customer service department will be pleased to assist you with your maintenance needs.

17. STORAGE

- Store the product in a safe, dry (not damp) place when not in use.
- DO NOT place heavy objects on the table during storage.
- If the product becomes damp or wet, wipe off the metal and plastic parts and allow to air dry before storing.

18. REUSE BY A NEW USER

This product can be reused by a new user. Before passing it on to the next user, the product must always be thoroughly cleaned and disinfected. Wear and tear must be checked by trained specialist personnel. Any damage must be rectified to ensure continued safe use of the product by the new user. The operating instructions are part of the product and must be passed on to the new user. Product settings must be adapted to the body dimensions of the next user. If necessary, have the settings adjusted by a specialized technician or therapist.

 Manufacturer Name Address	 Serial Number	 Medical Device	 Weight Capacity
 Do not use if package is damaged and consult instructions for use	 Non-Sterile	 Caution	 Read the instructions before use
 Machine wash-water temperature 30°	 Do not bleach	 Drip dry	 Do not iron
 Do not dry clean			

19. TECHNICAL SPECIFICATIONS

	VERTIFLEX Multi-positioning standing frame		
	SIZE 4	SIZE 5	SIZE 6
User size and weight			
User height (floor to axilla)	106.7cm-132.1cm (42"-52")	119.4 cm-144.8 cm (47"-57")	137.2 cm-162.6 cm (54"-64")
Maximum user weight	113 kg (250 lbs)	113 kg (250 lbs)	113 kg (250 lbs)
Chest			
Chest width	14 cm-45.7 cm (5.5"-18")	14 cm-45.7 cm (5.5"-18")	14 cm-45.7 cm (5.5"-18")
Chest support height	12.7cm (5")	12.7 cm (5")	12.7 cm (5")
Hip			
Hip width	14 cm-45.7 cm (5.5"-18")	14 cm-45.7 cm (5.5"-18")	14 cm-45.7 cm (5.5"-18")
Hip support height	12.7 cm (5")	12.7 cm (5")	12.7 cm (5")
Base			
Base width	65.4 cm (25 3/4")	65.4 cm (25 3/4")	65.4 cm (25 3/4")
Base length	109.2 cm (43")	109.2 cm (43")	109.2 cm (43")
Tray			
Inner tray width	61 cm (24")	61 cm (24")	61 cm (24")
Inner tray length	50.8 cm (20")	50.8 cm (20")	50.8 cm (20")
Tray tilt angle range	0 to 25 degrees	0 to 25 degrees	0 to 25 degrees
Knee			
Knee width	3.8 cm-8.9 cm (1.5"-3.5")	6.4 cm-10.1 cm (2.5"-4")	6.4 cm-14 cm (2.5"-5.5")
Knee support height	10.2 cm (4.5")	10.2 cm (4.5")	10.2 cm (4.5")
Foot plate			
Foot plate dimension (width X length)	45.7 cm x 40.6 cm (18.5" x 16")	45.7 cm x 40.6 cm (18.5" x 16")	45.7 cm x 40.6 cm (18.5" x 16")
Other			
Frame tilt range	0 to 90 degrees	0 to 90 degrees	0 to 90 degrees
Measurement from floor to foot plate	10.1cm (4.5")	10.1 cm (4.5")	10.1cm (4.5")
Overall width	65.4 cm (25 3/4")	65.4 cm (25 3/4")	65.4 cm (25 3/4")
Overall length	109.2 cm (43")	109.2 cm (43")	109.2 cm (43")



1242, rue de Lanaudière
Joliette (Quebec)
Canada J6E 3P1



1-450-759-9449
1-866-739-2400



www.synetikergocare.com



Printed in Canada

Synetik
ErgoCare

Stand **up**
Strong